

North Star Water Treatment Systems **PROFESSIONAL ADVANTAGE** COMMERCIAL SERIES WATER SOFTENERS – 1-1/2" VALVE

NOTE: All models shipped unassembled. Shipping weights are approximate.

MODEL	RESIN TANK	SHIPPING WEIGHT
PA1015S	17" x 58" P/N 7149994	440#
PA1015S-1	16" x 65" P/N 7391787	
PA1315S	17" x 58" P/N 7149994	500#
PA1315S-1	16" x 65" P/N 7391787	

MODEL	RESIN TANK	SHIPPING WEIGHT
PA1015D	17" x 58" P/N 7149994	850#
PA1015D-1	16" x 65" P/N 7391787	
PA1315D	17" x 58" P/N 7149994	960#
PA1315D-1	16" x 65" P/N 7391787	

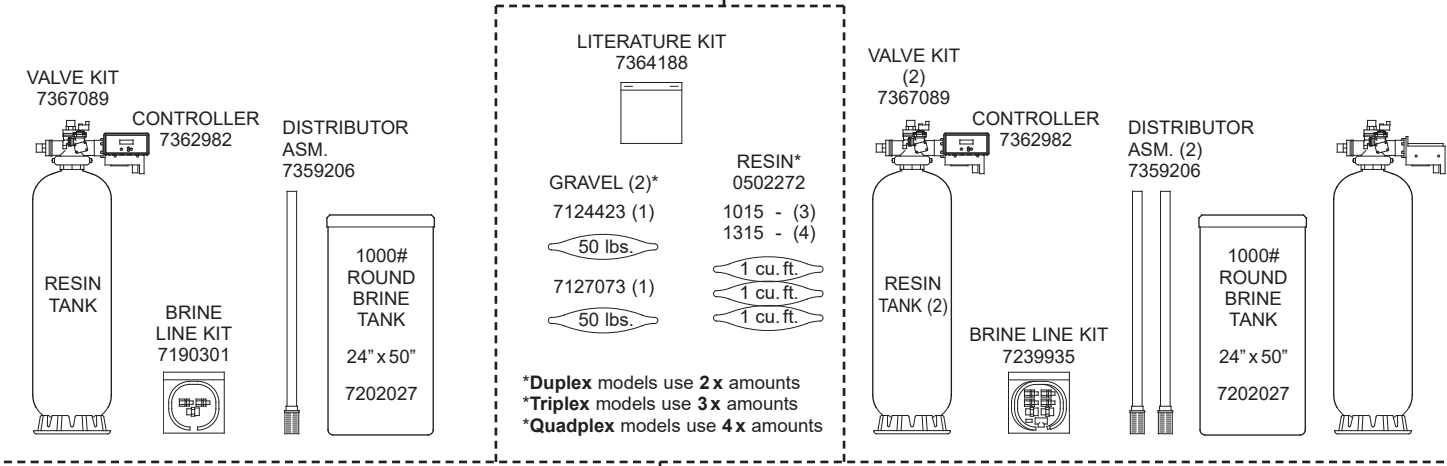

MODEL	RESIN TANK	SHIPPING WEIGHT
PA1015T	17" x 58" P/N 7149994	1290#
PA1015T-1	16" x 65" P/N 7391787	
PA1315T	17" x 58" P/N 7149994	1450#
PA1315T-1	16" x 65" P/N 7391787	

MODEL	RESIN TANK	SHIPPING WEIGHT
PA1015Q	17" x 58" P/N 7149994	1780#
PA1015Q-1	16" x 65" P/N 7391787	
PA1315Q	17" x 58" P/N 7149994	1870#
PA1315Q-1	16" x 65" P/N 7391787	

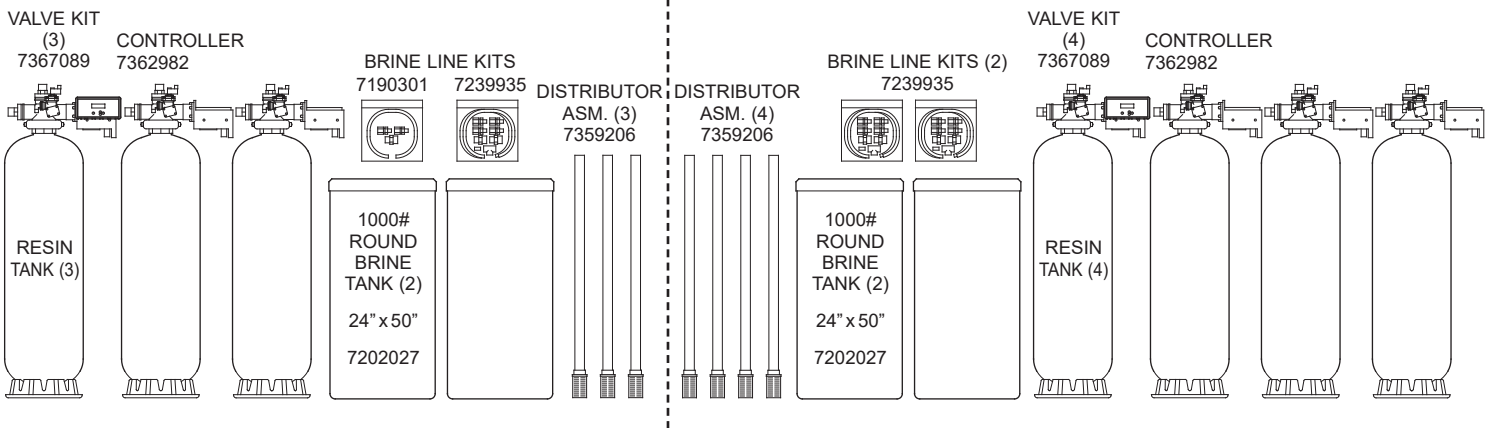

North Star Water Treatment Systems PROFESSIONAL ADVANTAGE COMMERCIAL SERIES WATER SOFTENERS – 1-1/2" VALVE

NOTE: All models shipped unassembled. Shipping weights are approximate.

MODEL	RESIN TANK	SHIPPING WEIGHT
PA1615S	17" x 72" P/N 7153561	600#
PA1615S-1	18" x 65" P/N 7391795	

MODEL	RESIN TANK	SHIPPING WEIGHT
PA1615D	17" x 72" P/N 7153561	1090#
PA1615D-1	18" x 65" P/N 7391795	

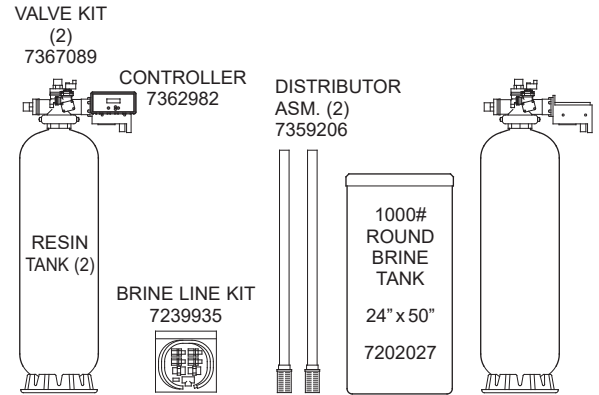
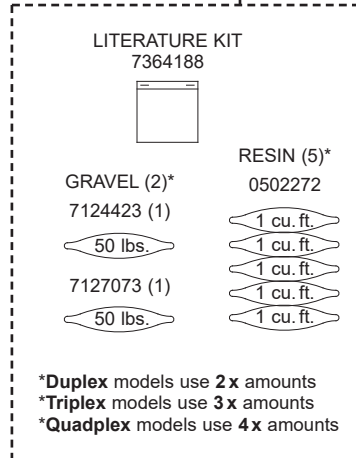
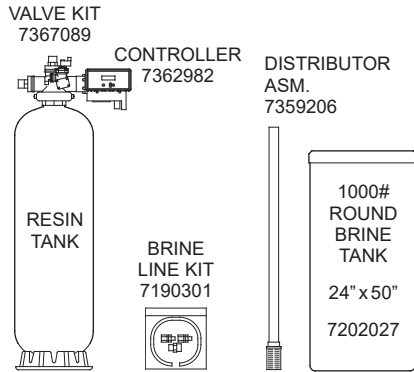

MODEL	RESIN TANK	SHIPPING WEIGHT
PA1615T	17" x 72" P/N 7153561	1640#
PA1615T-1	18" x 65" P/N 7391795	

MODEL	RESIN TANK	SHIPPING WEIGHT
PA1615Q	17" x 72" P/N 7153561	2130#
PA1615Q-1	18" x 65" P/N 7391795	

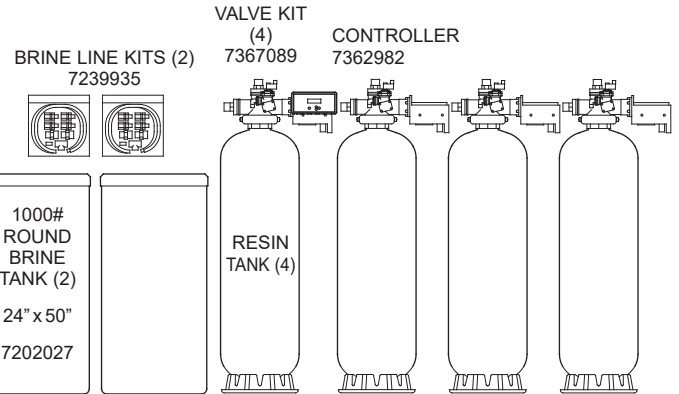
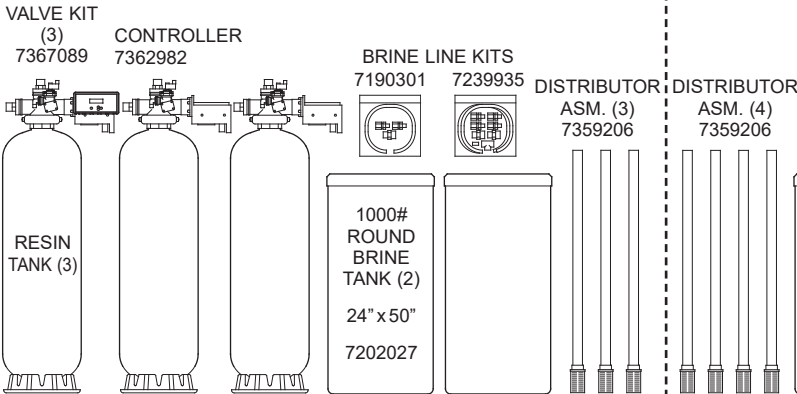

North Star Water Treatment Systems PROFESSIONAL ADVANTAGE COMMERCIAL SERIES WATER SOFTENERS – 1-1/2" VALVE

NOTE: All models shipped unassembled. Shipping weights are approximate.

MODEL	RESIN TANK	SHIPPING WEIGHT
PA1915S	24" x 72" P/N 7298777	820#
PA1915S-1	24" x 72" P/N 7391800	
PA2515S	24" x 72" P/N 7298777	920#
PA2515S-1	24" x 72" P/N 7391800	
PA3215S	24" x 72" P/N 7298777	1030#
PA3215S-1	24" x 72" P/N 7391800	

MODEL	RESIN TANK	SHIPPING WEIGHT
PA1915D	24" x 72" P/N 7298777	1490#
PA1915D-1	24" x 72" P/N 7391800	
PA2515D	24" x 72" P/N 7298777	1710#
PA2515D-1	24" x 72" P/N 7391800	
PA3215D-	24" x 72" P/N 7298777	1920#
PA3215D-1	24" x 72" P/N 7391800	

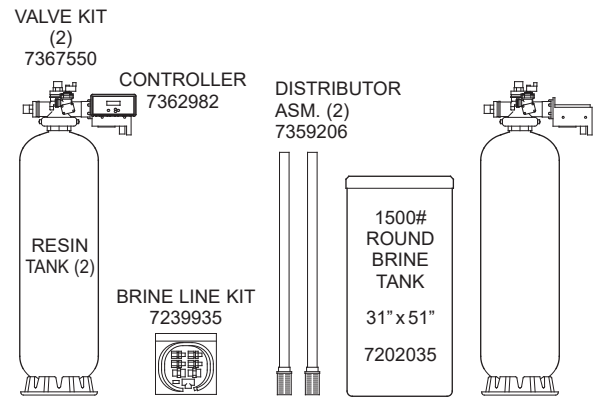
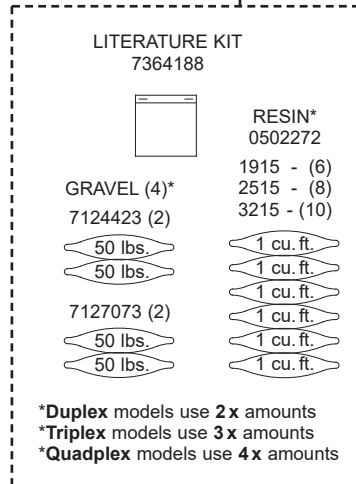
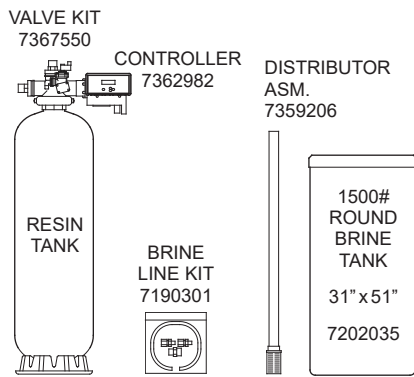

MODEL	RESIN TANK	SHIPPING WEIGHT
PA1915T	24" x 72" P/N 7298777	2260#
PA1915T-1	24" x 72" P/N 7391800	
PA2515T	24" x 72" P/N 7298777	2590#
PA2515T-1	24" x 72" P/N 7391800	
PA3215T	24" x 72" P/N 7298777	2910#
PA3215T-1	24" x 72" P/N 7391800	

MODEL	RESIN TANK	SHIPPING WEIGHT
PA1915Q	24" x 72" P/N 7298777	2940#
PA1915Q-1	24" x 72" P/N 7391800	
PA2515Q	24" x 72" P/N 7298777	3410#
PA2515Q-1	24" x 72" P/N 7391800	
PA3215Q	24" x 72" P/N 7298777	3840#
PA3215Q-1	24" x 72" P/N 7391800	

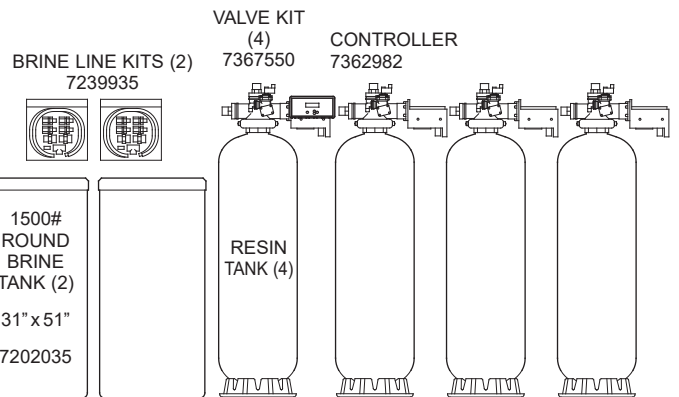
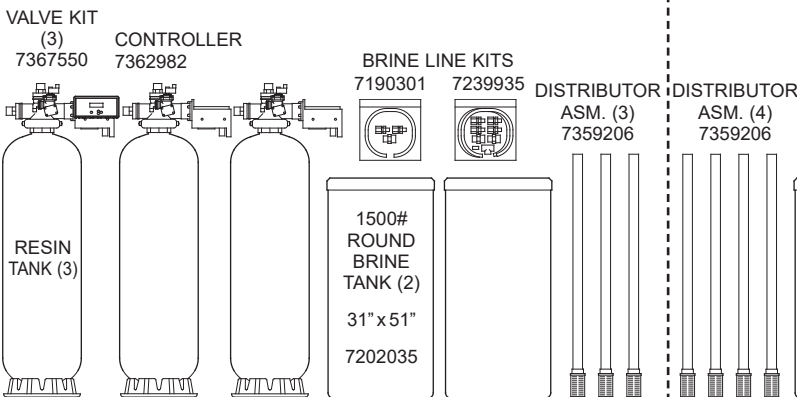

North Star Water Treatment Systems **PROFESSIONAL ADVANTAGE** COMMERCIAL SERIES WATER FILTERS – 1-1/2" VALVE

NOTE: All models shipped unassembled. Shipping weights are approximate.

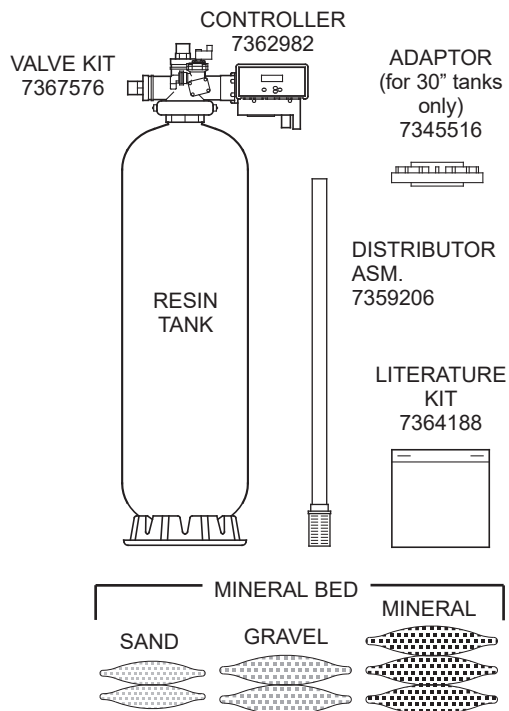

MODEL	RESIN TANK	SHIPPING WEIGHT	MINERAL BED
PA1715XS	17" x 58" P/N 7149994	252#	see table below
PA1715XS-1	16" x 65" P/N 7391787		
PA2415XS	24" x 72" P/N 7298777	358#	
PA2415XS-1	24" x 72" P/N 7391800		
PA3015XS	30" x 72" P/N 0403007	765#	
PA1715CS	17" x 58" P/N 7149994	420#	
PA1715CS-1	16" x 65" P/N 7391787		
PA2415CS	24" x 72" P/N 7298777	770#	
PA2415CS-1	24" x 72" P/N 7391800		
PA3015CS	30" x 72" P/N 0403007	1185#	
PA1715MS	17" x 58" P/N 7149994	560#	
PA1715MS-1	16" x 65" P/N 7391787		
PA2415MS	24" x 72" P/N 7298777	1060#	
PA2415MS-1	24" x 72" P/N 7391800		
PA1715GS	17" x 58" P/N 7149994	660#	
PA1715GS-1	16" x 65" P/N 7391787		
PA2415GS	24" x 72" P/N 7298777	1160#	
PA2415GS-1	24" x 72" P/N 7391800		

	MODEL	GRAVEL 7124423		FILTER SAND 0993080		ACTIVATED CARBON 7336834	GREENSAND PLUS™ 7331101	ANTHRACITE 0993070		GARNET 0993090	
		lbs.	bags	lbs.	bags	1 cu. ft. bags	1/2 cu. ft. bags	lbs.	bags	lbs.	bags
Mineral Bed	PA1715XS, PA1715XS-1	100	2	–	–	–	–	–	–	–	–
	PA2415XS, PA2415XS-1	150	3	–	–	–	–	–	–	–	–
	PA3015XS	250	5	–	–	–	–	–	–	–	–
	PA1715CS, PA1715CS-1	100	2	–	–	4	–	–	–	–	–
	PA2415CS, PA2415CS-1	150	3	–	–	10	–	–	–	–	–
	PA3015CS	250	5	–	–	15	–	–	–	–	–
	PA1715MS, PA1715MS-1	100	2	100	2	–	–	156	3	50	1
	PA2415MS, PA2415MS-1	150	3	250	5	–	–	312	6	150	3
	PA1715GS, PA1715GS-1	100	2	–	–	–	6	78*	2*	50	1
	PA2415GS, PA2415GS-1	150	3	–	–	–	12	156	3	150	3

Greensand Plus™ is a trademark of Inversand Company.

*1-1/2 of the 2 bags included are used.

North Star Water Treatment Systems **PROFESSIONAL ADVANTAGE** COMMERCIAL SERIES WATER FILTERS – 1-1/2" VALVE

NOTE: All models shipped unassembled. Shipping weights are approximate.

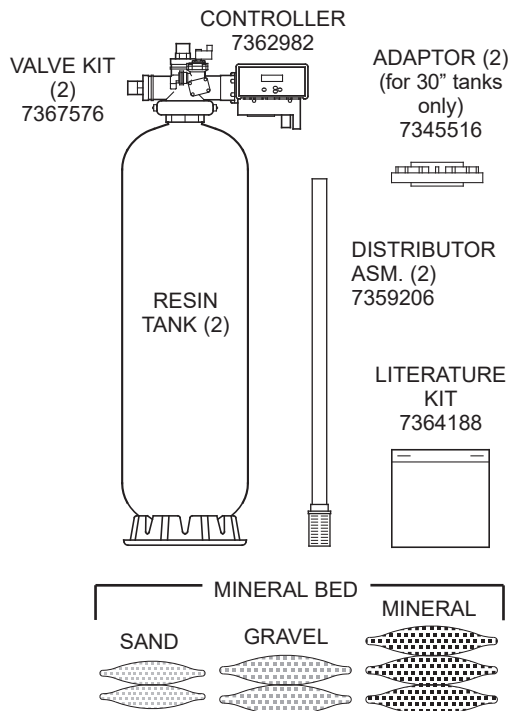

MODEL	RESIN TANK	SHIPPING WEIGHT	MINERAL BED
PA1715XD	17" x 58" P/N 7149994	494#	see table below
PA1715XD-1	16" x 65" P/N 7391787		
PA2415XD	24" x 72" P/N 7298777	680#	
PA2415XD-1	24" x 72" P/N 7391800		
PA3015XD	30" x 72" P/N 0403007	1480#	
PA1715CD	17" x 58" P/N 7149994	830#	
PA1715CD-1	16" x 65" P/N 7391787		
PA2415CD	24" x 72" P/N 7298777	1570#	
PA2415CD-1	24" x 72" P/N 7391800		
PA3015CD	30" x 72" P/N 0403007	2320#	
PA1715MD	17" x 58" P/N 7149994	1110#	
PA1715MD-1	16" x 65" P/N 7391787		
PA2415MD	24" x 72" P/N 7298777	2110#	
PA2415MD-1	24" x 72" P/N 7391800		
PA1715GD	17" x 58" P/N 7149994	1260#	
PA1715GD-1	16" x 65" P/N 7391787		
PA2415GD	24" x 72" P/N 7298777	2320#	
PA2415GD-1	24" x 72" P/N 7391800		

MODEL	GRAVEL 7124423		FILTER SAND 0993080		ACTIVATED CARBON 7336834	GREENSAND PLUS™ 7331101	ANTHRACITE 0993070		GARNET 0993090	
	lbs.	bags	lbs.	bags	1 cu. ft. bags	1/2 cu. ft. bags	lbs.	bags	lbs.	bags
PA1715XD, PA1715XD-1	200	4	–	–	–	–	–	–	–	–
PA2415XD, PA2415XD-1	300	6	–	–	–	–	–	–	–	–
PA3015XD	500	10	–	–	–	–	–	–	–	–
PA1715CD, PA1715CD-1	200	4	–	–	8	–	–	–	–	–
PA2415CD, PA2415CD-1	300	6	–	–	20	–	–	–	–	–
PA3015CD	500	10	–	–	30	–	–	–	–	–
PA1715MD, PA1715MD-1	200	4	200	4	–	–	312	6	100	2
PA2415MD, PA2415MD-1	300	6	500	10	–	–	624	12	300	6
PA1715GD, PA1715GD-1	200	4	–	–	–	12	156	3	100	2
PA2415GD, PA2415GD-1	300	6	–	–	–	24	312	6	300	6

Greensand Plus™ is a trademark of Inversand Company.

North Star Water Treatment Systems PROFESSIONAL ADVANTAGE COMMERCIAL SERIES WATER FILTERS – 1-1/2" VALVE

NOTE: All models shipped unassembled. Shipping weights are approximate.

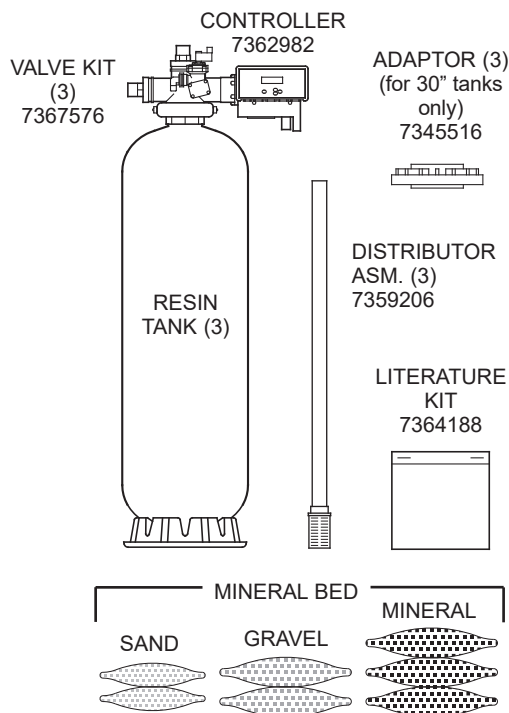

MODEL	RESIN TANK	SHIPPING WEIGHT	MINERAL BED
PA1715XT	17" x 58" P/N 7149994	746#	see table below
PA1715XT-1	16" x 65" P/N 7391787		
PA2415XT	24" x 72" P/N 7298777	1060#	
PA2415XT-1	24" x 72" P/N 7391800		
PA3015XT	30" x 72" P/N 0403007	2240#	
PA1715CT	17" x 58" P/N 7149994	1250#	
PA1715CT-1	16" x 65" P/N 7391787		
PA2415CT	24" x 72" P/N 7298777	2320#	
PA2415CT-1	24" x 72" P/N 7391800		
PA3015CT	30" x 72" P/N 0403007	3500#	
PA1715MT	17" x 58" P/N 7149994	1660#	
PA1715MT-1	16" x 65" P/N 7391787		
PA2415MT	24" x 72" P/N 7298777	3200#	
PA2415MT-1	24" x 72" P/N 7391800		
PA1715GT	17" x 58" P/N 7149994	1920#	
PA1715GT-1	16" x 65" P/N 7391787		
PA2415GT	24" x 72" P/N 7298777	3480#	
PA2415GT-1	24" x 72" P/N 7391800		

MODEL	GRAVEL 7124423		FILTER SAND 0993080		ACTIVATED CARBON 7336834	GREENSAND PLUS™ 7331101	ANTHRACITE 0993070		GARNET 0993090	
	lbs.	bags	lbs.	bags	1 cu. ft. bags	1/2 cu. ft. bags	lbs.	bags	lbs.	bags
PA1715XT, PA1715XT-1	300	6	-	-	-	-	-	-	-	-
PA2415XT, PA2415XT-1	450	9	-	-	-	-	-	-	-	-
PA3015XT	750	15	-	-	-	-	-	-	-	-
PA1715CT, PA1715CT-1	300	6	-	-	12	-	-	-	-	-
PA2415CT, PA2415CT-1	450	9	-	-	30	-	-	-	-	-
PA3015CT	750	15	-	-	45	-	-	-	-	-
PA1715MT, PA1715MT-1	300	6	300	6	-	-	468	9	150	3
PA2415MT, PA2415MT-1	450	9	750	15	-	-	936	18	450	9
PA1715GT, PA1715GT-1	300	6	-	-	-	18	234*	5*	150	3
PA2415GT, PA2415GT-1	450	9	-	-	-	36	468	9	450	9

Greensand Plus™ is a trademark of Inversand Company.

*4-1/2 of the 5 bags included are used.

North Star Water Treatment Systems **PROFESSIONAL ADVANTAGE** COMMERCIAL SERIES WATER FILTERS – 1-1/2" VALVE

NOTE: All models shipped unassembled. Shipping weights are approximate.

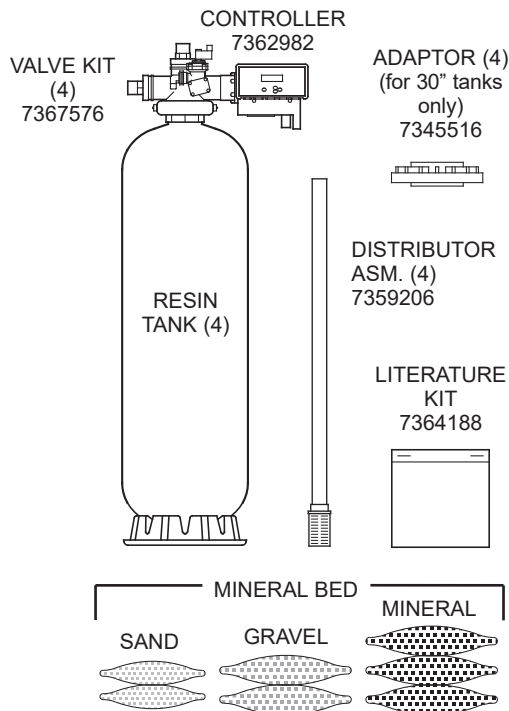

MODEL	RESIN TANK	SHIPPING WEIGHT	MINERAL BED
PA1715XQ	17" x 58" P/N 7149994	988#	see table below
PA1715XQ-1	16" x 65" P/N 7391787		
PA2415XQ	24" x 72" P/N 7298777	1370#	
PA2415XQ-1	24" x 72" P/N 7391800		
PA3015XQ	30" x 72" P/N 0403007	3060#	
PA1715CQ	17" x 58" P/N 7149994	2080#	
PA1715CQ-1	16" x 65" P/N 7391787		
PA2415CQ	24" x 72" P/N 7298777	3050#	
PA2415CQ-1	24" x 72" P/N 7391800		
PA3015CQ	30" x 72" P/N 0403007	4740#	
PA1715MQ	17" x 58" P/N 7149994	2210#	
PA1715MQ-1	16" x 65" P/N 7391787		
PA2415MQ	24" x 72" P/N 7298777	4250#	
PA2415MQ-1	24" x 72" P/N 7391800		
PA1715GQ	17" x 58" P/N 7149994	2520#	
PA1715GQ-1	16" x 65" P/N 7391787		
PA2415GQ	24" x 72" P/N 7298777	4670#	
PA2415GQ-1	24" x 72" P/N 7391800		

MODEL	GRAVEL 7124423		FILTER SAND 0993080		ACTIVATED CARBON 7336834	GREENSAND PLUS™ 7331101	ANTHRACITE 0993070		GARNET 0993090	
	lbs.	bags	lbs.	bags	1 cu. ft. bags	1/2 cu. ft. bags	lbs.	bags	lbs.	bags
PA1715XQ, PA1715XQ-1	400	8	–	–	–	–	–	–	–	–
PA2415XQ, PA2415XQ-1	600	12	–	–	–	–	–	–	–	–
PA3015XQ	1000	20	–	–	–	–	–	–	–	–
PA1715CQ, PA1715CQ-1	400	8	–	–	16	–	–	–	–	–
PA2415CQ, PA2415CQ-1	600	12	–	–	40	–	–	–	–	–
PA3015CQ	1000	20	–	–	60	–	–	–	–	–
PA1715MQ, PA1715MQ-1	400	8	400	8	–	–	624	12	200	4
PA2415MQ, PA2415MQ-1	600	12	1000	20	–	–	1248	24	600	12
PA1715GQ, PA1715GQ-1	400	8	–	–	–	24	312	6	200	4
PA2415GQ, PA2415GQ-1	600	12	–	–	–	48	624	12	600	12

Greensand Plus™ is a trademark of Inversand Company.

North Star Water Treatment Systems **PROFESSIONAL ADVANTAGE** COMMERCIAL SERIES WATER FILTERS – 1-1/2” VALVE

BEDDING SEQUENCE OF GRAVEL & MINERALS

NOTE: Be sure distributor assembly is centered in tank before filling.

**NO MEDIA
(GRAVEL ONLY) FILTERS**

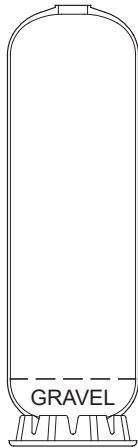

CARBON FILTERS

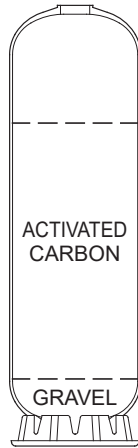

MULTI-MEDIA FILTERS



**GREENSAND PLUS™
FILTERS**



North Star Water Treatment Systems **PROFESSIONAL ADVANTAGE** COMMERCIAL SERIES – 1-1/2” VALVE

1-1/2” Valve Kits (as shipped)

Valve Kit	Used on	Valve	Aspirator	Filter Kit	Water Meter	Parts Kit	Clamp Kit
7367089	Softeners with 16” or 17” dia. resin tank	7367306	7367102	–	7361457	7367322	7367631
7367550	Softeners w/24” dia. resin tank	7367306	7367110	–	7361457	7367322	7367631
7367568	Softeners w/30” dia. resin tank	7367306	7367128	–	7361457	7367322	7367631
7367576	Filters	7367306	–	7367136	7361457	7367322	7367631

Media

	Part Number	Weight (lbs.)
Resin	0502272	53
Gravel, Quartz	7124415	17
	7124423	50
Gravel, Medium	7127073	50
Anthracite	0993070	52
Garnet	0993090	50
Sand, Filter	0993080	50
Carbon, Activated	7336834	27.5
Greensand Plus™	7331101	44

Greensand Plus™ is a trademark of Inversand Company.

Accessories & 1-1/2” Valve Repair Parts Kits

	Part Number
External No Hard Water Shutoff for 1-1/2” Valve, DC	7383051
Piston Plug, Multi-Tank	7367445
Drive Assembly, 1-1/2” Valve	7367437
Aspirator Kit, 1-1/2” Valve	7367429
Kit, Neck O-Ring	7367411
Kit, Installation Clips & O-Rings	7367372
Rebuild Kit, Internal Rubber Parts	7367398
Rebuild Kit, Internal, Lantern Ring & Rubber Parts	7367380