

## Central Water Whole Home Filtration System

The North Star NSWHCW Central Water Filtration System is the Maintenance-Free choice for residential homes. NSF certified for performance, this system provides filtered water throughout your entire home, without filters to replace. North Star's 100 years of expertise in water treatment will ensure top-notch performance and a responsive, U.S.-based customer service team, will offer reliable assistance for any inquiries or needs.

### FEATURES

- Reduces chlorine and sediment from the water supply, perfect for municipal water
- System automatically flushes, cleans and drains its internal filter every 14 days
- High-flow valve maintains water pressure throughout the home, including your shower and appliances
- Connects with up to 1" plumbing
- Includes: Installation kit



REDUCES  
CHLORINE



REDUCES  
SEDIMENT

# CENTRAL WATER WHOLE HOME FILTRATION SYSTEM NSWHCW

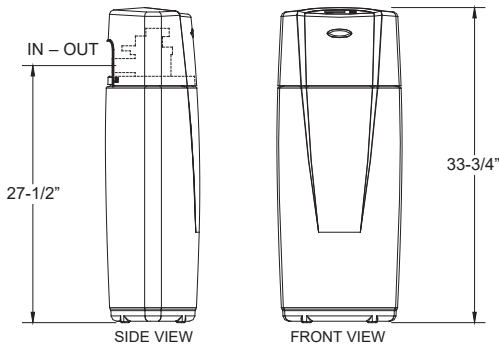
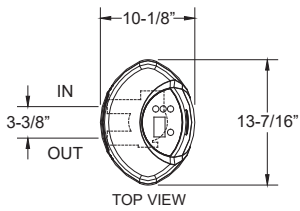

## SPECIFICATIONS

Model Number	NSWHCW
Part Number	7358179
Flow Rate	6 gpm
Water Pressure Limits	30 - 125 psi
Water Temperature Limits	40 - 100*F
Drain Flow Rate	3.4 gpm
Estimated Total Capacity	570,000 gallons
NSF Certification	NSF/ANSI 42, CSA B483.1

## WARRANTY

**1 year** on all parts | **5 year** electronic control board | **10 year** on media tank



Systems tested and certified by NSF International against NSF/ANSI Standard 42 for hardness reduction of chlorine taste and odor, and certified to NSF/ANSI/CAN Standard 372.



Systems tested and certified by the Water Quality Association against CSA B483.1.

## FOR MORE INFORMATION

### EMAIL

[info@northstarwater.com](mailto:info@northstarwater.com)

### VISIT

[www.northstarwater.com](http://www.northstarwater.com)

## WARRANTY

Warrantor guarantees, to the original owner, that for a period of one (1) year from the date of purchase, all parts will be free from defects in materials and workmanship and will perform their normal functions. For a period of ten (10) years from the date of purchase, the fiberglass media tank will not rust, corrode, leak, burst or in any other manner, fail to perform their proper functions. For a period of five (5) years from the date of purchase, the electronic control board and valve body will be free of defects in materials and workmanship and will perform their normal functions. If, during such respective period, a part proves to be defective, Warrantor will ship a replacement part directly to your home, without charge.