



Full Flow

Drinking Water Filtration System

The North Star NSDW300 Full Flow Water Filtration System is the economical choice for residential homes. With NSF certification ensuring advanced contaminant reduction, this system reduces harmful contaminants like Chlorine Taste and Odor, Sediment, and Microplastics, delivering healthier, great-tasting water to refrigerators and any sink in the home. North Star products draw on 100 years of experience, and their U. S.-based customer service team is ready to assist with any future inquiries or needs.

Features

- No faucet required
- Includes everything needed for installation
- Includes one-year limited warranty
- Compatible with North Star filters: NSDW300R



Reduces



CHLORINE



SEDIMENT &
MICROPLASTICS



NSDW300R

- Full Flow Water Filtration System (NSDW300)
- Filter Life: 2,000 gallons or 6 months
- Twist-and-pull design for easy filter replacement
- Contaminant reduction: Chlorine Taste and Odor, Sediment, Cysts, Lead, Chemicals

FULL FLOW DRINKING WATER FILTRATION SYSTEM NSDW300

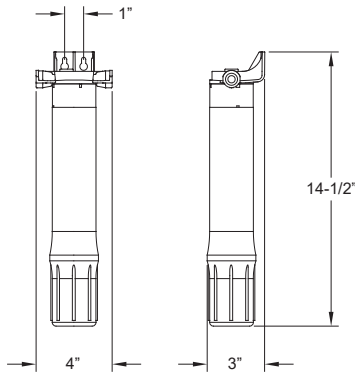

SPECIFICATIONS

Model Number	NSDW300
Part Number	7358276
For Use with Filters	NSDW300R (7358284)
Min. - Max. Supply Water Pressure	30 - 100 psi (280 - 689 kPa)
Min. - Max. Supply Water Temperature	40 - 100°F (4 - 38°C)
Inlet - Outlet	3/8" Quick Connect
Flow Rate (gpm)	Up to 2.0
NSF Certification	42, 401, 372
WARRANTY	
1 year parts warranty	•



System tested and certified by NSF International against NSF/ANSI Standards 42 and 401 for the reduction of claims specified on the performance data sheet at www.nsf.org. System tested and certified to CSA B483.1 and NSF/ANSI/CAN 372.

FOR MORE INFORMATION
www.northstarwater.com

ONE YEAR LIMITED WARRANTY ON UNDERSINK DRINKING WATER FILTER SYSTEM (except filter cartridges)

Warrantor guarantees, to the original owner, that the Undersink Drinking Water Filter System, when installed and maintained in accordance with the instructions, will be free from defects in materials and workmanship for a period of one (1) year from the date of purchase. If, within the first year, a part proves, after inspection, to be defective, Warrantor will, at its sole option, either replace or repair the part without charge except normal shipping and installation charges. Labor to maintain the equipment is not part of the warranty. Filters, which are expendable, are not covered by the warranty.